

4

3

2

1

REVISIONS				
ZONE	REV.	DESCRIPTION	DATE	CHECKED

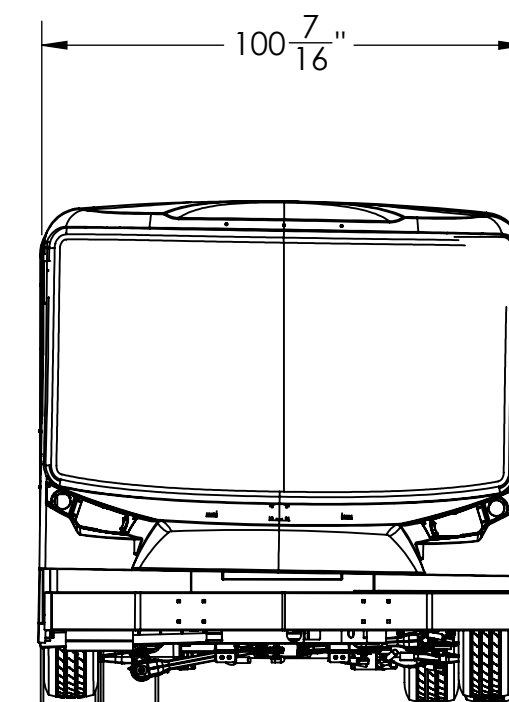
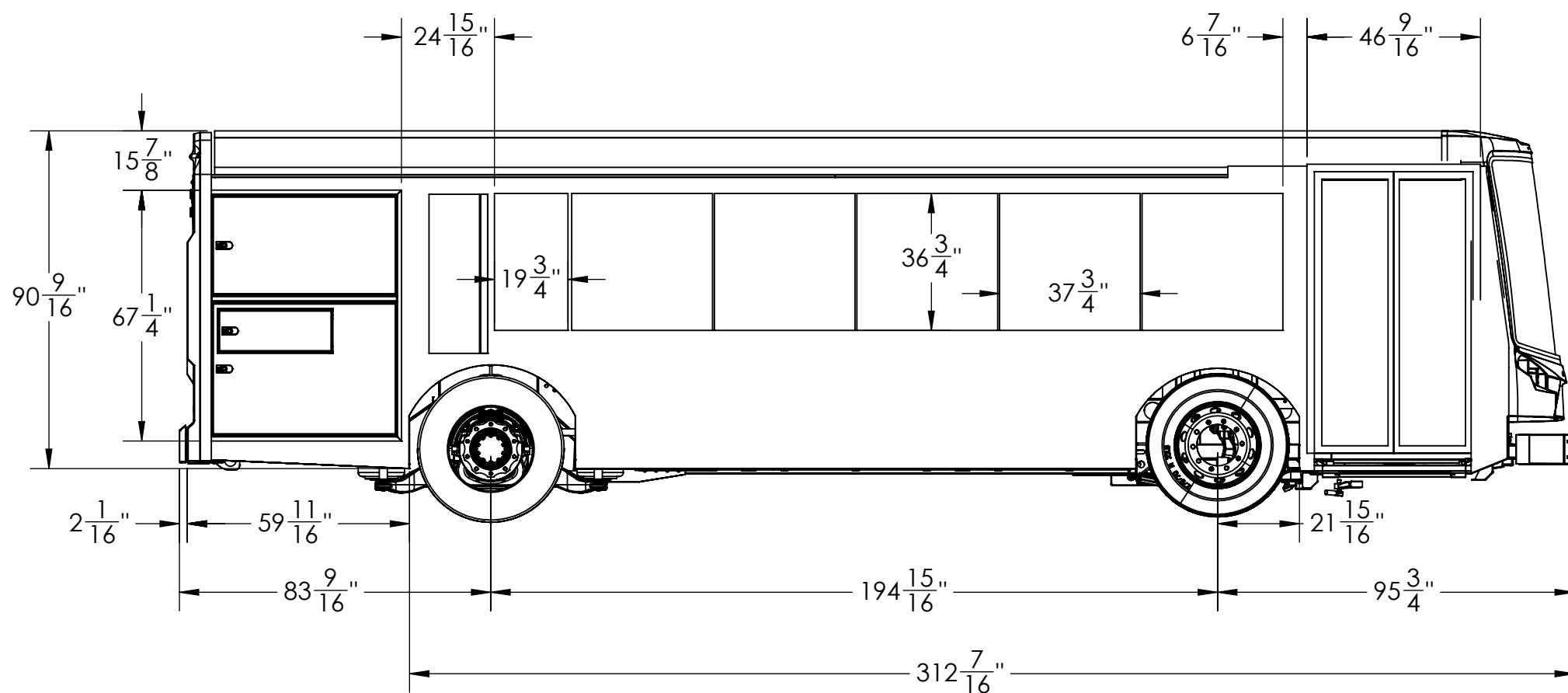
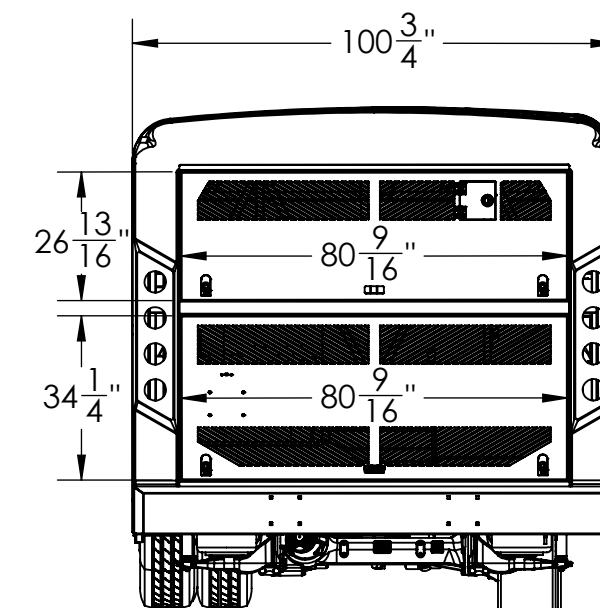
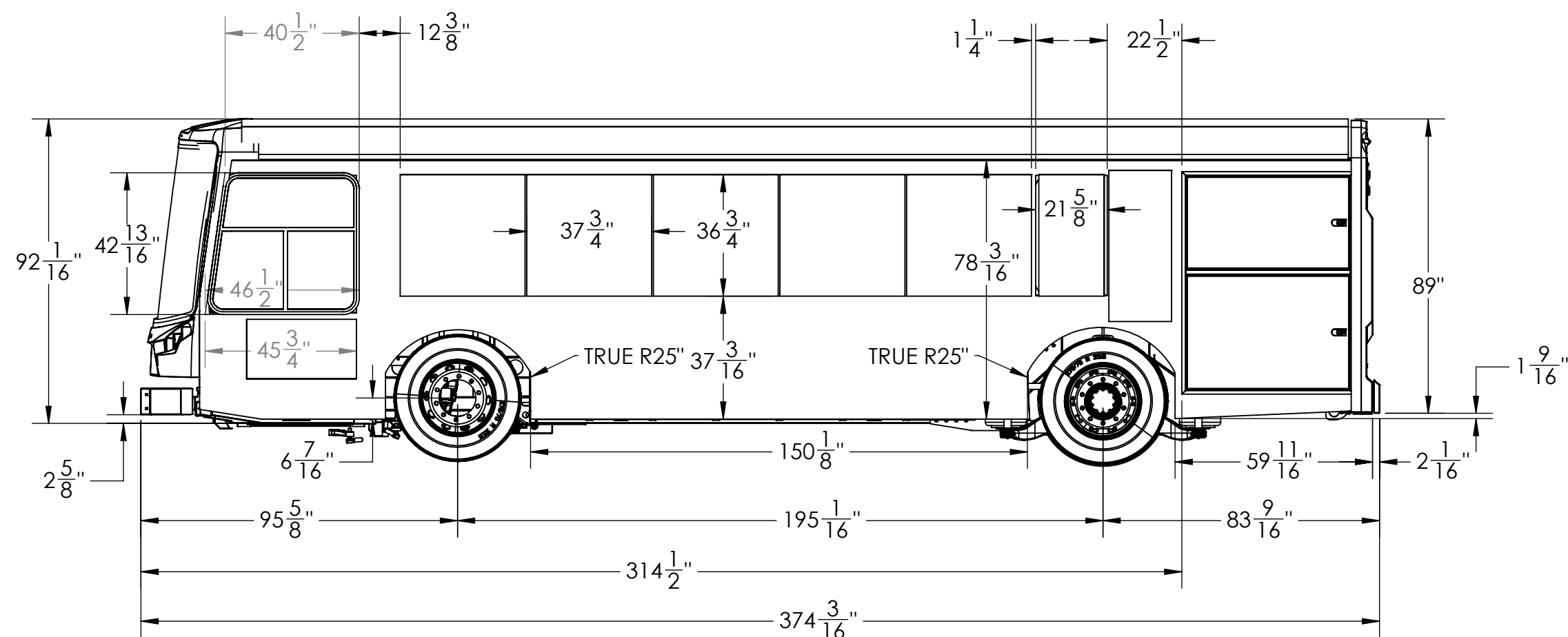

**TOLERANCES UNLESS OTHERWISE NOTED:**

- +/- 1/8" Overall Assembly
- +/- 1/16" Hole/Slot Location
- +/- 0.03 Hole/Slot Size
- +/- 1 Deg for Angle Dims

ARBOC SPECIALTY VEHICLES CLAIMS PROPRIETARY RIGHTS IN THE MATERIAL DISCLOSED HEREON. NEITHER THIS DRAWING NOR ANY REPRODUCTION THEREOF MAY BE USED TO MANUFACTURE ANYTHING SHOWN HEREON WITHOUT PERMISSION IN WRITING FROM ARBOC SPECIALTY VEHICLES TO THE USER SPECIFICALLY REFERRING TO THE DRAWINGS. INFORMATION CONTAINED HEREON MAY BE THE EXPRESS PROPERTY OF ARBOC SPECIALTY VEHICLES AND PROTECTED IN THE FORM OF A U.S. PATENT.



<b>MATERIAL: See BOM</b>	
FINISH WEIGHT: 9174.86 lbs	
FINISH:	

MODELED:	SIGNATURES/DATES
DRAWN:	
CHECKED:	

DESCRIPTION: 30FT DIESEL EQUESS ELVATION, 22.5 WHEEL 1 DOOR			
PART NUMBER:	DRAWING SIZE: C	SHEET: 1 OF 2	SCALE: 1:40

4

3

2

1